

PMX-R/PMXS-R 分度柱塞 - 环型

SUS 不锈钢

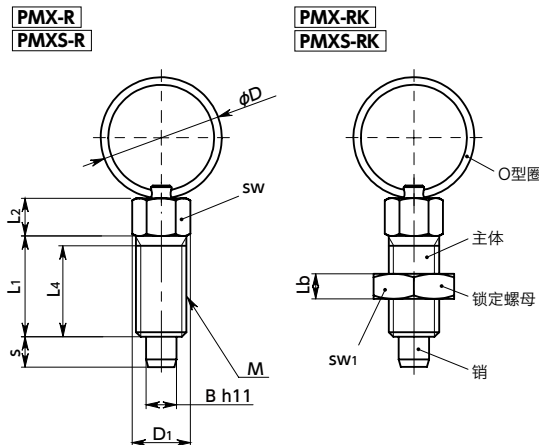

● 型号指定

PMXS-5-M10-1-RK

● 强度

型号	型号	容许紧固扭矩 (N·m)
PMX-3-M6	PMXS-3-M6	2
PMX-3-M6-0.75	PMXS-3-M6-0.75	3
PMX-4-M6	PMXS-4-M6	2
PMX-4-M8-1	PMXS-4-M8-1	8
PMX-5-M8	PMXS-5-M8	7
PMX-5-M8-1	PMXS-5-M8-1	7
PMX-5-M10-1	PMXS-5-M10-1	22
PMX-6-M10	PMXS-6-M10	15
PMX-6-M12-1.5	PMXS-6-M12-1.5	38
PMX-8-M12	PMXS-8-M12	20
PMX-8-M12-1.5	PMXS-8-M12-1.5	20
PMX-8-M16-1.5	PMXS-8-M16-1.5	80
PMX-10-M16-1.5	PMXS-10-M16-1.5	80

⚠ 由于可能导致螺纹部破损，紧固时请确保锁定螺母的紧固扭矩不超过上表中的数值。

- 构造简单的分度柱塞。
- 性价比优良。
- 销径 $\phi 3 - \phi 10$ 、主体螺纹直径 M6-M16 已实现标准化。M6-M12 分为粗牙和细牙。
- 可根据产品符号选择主体材质及锁定螺母的有无。

产品符号	主体材质	锁定螺母
PMX-R	钢	无*1
PMX-RK	钢	有
PMXS-R	不锈钢	无*1
PMXS-RK	不锈钢	有

*1: 请使用防松件服务。(→ P.xxxx)

● 材质、表面处理

	PMX-R	PMX-RK	PMXS-R	PMXS-RK
环	SUS301	SUS301	SUS301	SUS301
主体	SUM22L 三价铬酸盐处理	SUM22L 三价铬酸盐处理	SUS303	SUS303
销	SUS303	SUS303	SUS303	SUS303
弹簧	SUS301	SUS301	SUS301	SUS301
锁定螺母	-	S45C*1 三价铬酸盐处理	-	SUS303

*1: **PMX-3-M6-0.75-RK** 的锁定螺母材质为 SUS303。



PMX-R 无锁定螺母 PMX-RK 带锁定螺母

型号 钢制	B	s	M		D	D1	L1	L2	L4 min.	Lb	sw	sw1	载荷(N) min./max.	销的 剪切载荷(N)	适用轴环 [PXCS] → P.xxxx	质量(g)	
			螺纹公称直径	螺距													
PMX-3-M6-R	3	3.5	M6	1	粗牙	14	6.9	12	4.5	10	-	6	3/12	650	PXCS-6-7-**	4	
PMX-3-M6-0.75-R	3	3.5	M6	0.75	细牙	14	6.9	12	4.5	10	-	6	3/12	650	PXCS-6-7-**	4	
PMX-4-M6-R	4	4	M6	1	粗牙	14	6.9	12	4.5	10	-	6	3/12	1160	PXCS-6-7-**	4	
PMX-4-M8-1-R	4	4.5	M8	1	细牙	18	9.2	16	6	13.5	-	8	5/24	1160	PXCS-8-10-**	9	
PMX-5-M8-R	5	5	M8	1.25	粗牙	18	9.2	16	6	13.5	-	8	5/24	1820	PXCS-8-10-**	9	
PMX-5-M8-1-R	5	5	M8	1	细牙	18	9.2	16	6	13.5	-	8	5/24	1820	PXCS-8-10-**	9	
PMX-5-M10-1-R	5	5	M10	1	细牙	18	11.5	16	6	13.5	-	10	5/24	1820	PXCS-10-12-**	14	
PMX-6-M10-R	6	6	M10	1.5	粗牙	24	11.5	20	7.5	17	-	10	5/21	2620	PXCS-10-12-**	18	
PMX-6-M12-1.5-R	6	6	M12	1.5	细牙	24	13.8	20	7.5	16.5	-	12	5/21	2620	PXCS-12-14-**	26	
PMX-8-M12-R	8	8	M12	1.75	粗牙	30	13.8	24	9	20.5	-	12	6/22	4660	PXCS-12-14-**	32	
PMX-8-M12-1.5-R	8	8	M12	1.5	细牙	30	13.8	24	9	20.5	-	12	6/22	4660	PXCS-12-14-**	32	
PMX-8-M16-1.5-R	8	8	M16	1.5	细牙	30	19.6	24	9	20.5	-	17	6/22	4660	PXCS-16-17-**	57	
PMX-10-M16-1.5-R	10	10	M16	1.5	细牙	30	19.6	26	9	22.5	-	17	4/27	7280	PXCS-16-17-**	62	
PMX-3-M6-RK	3	3.5	M6	1	粗牙	14	6.9	12	4.5	10	3.2	6	10	3/12	650	PXCS-6-7-**	5
PMX-3-M6-0.75-RK	3	3.5	M6	0.75	细牙	14	6.9	12	4.5	10	3.2	6	10	3/12	650	PXCS-6-7-**	5
PMX-4-M6-RK	4	4	M6	1	粗牙	14	6.9	12	4.5	10	3.2	6	10	3/12	1160	PXCS-6-7-**	5
PMX-4-M8-1-RK	4	4.5	M8	1	细牙	18	9.2	16	6	13.5	4	8	13	5/24	1160	PXCS-8-10-**	12
PMX-5-M8-RK	5	5	M8	1.25	粗牙	18	9.2	16	6	13.5	4	8	13	5/24	1820	PXCS-8-10-**	12
PMX-5-M8-1-RK	5	5	M8	1	细牙	18	9.2	16	6	13.5	4	8	13	5/24	1820	PXCS-8-10-**	12
PMX-5-M10-1-RK	5	5	M10	1	细牙	18	11.5	16	6	13.5	5	10	16	5/24	1820	PXCS-10-12-**	20
PMX-6-M10-RK	6	6	M10	1.5	粗牙	24	11.5	20	7.5	17	5	10	17	5/21	2620	PXCS-10-12-**	25
PMX-6-M12-1.5-RK	6	6	M12	1.5	细牙	24	13.8	20	7.5	16.5	6	12	18	5/21	2620	PXCS-12-14-**	36
PMX-8-M12-RK	8	8	M12	1.75	粗牙	30	13.8	24	9	20.5	6	12	19	6/22	4660	PXCS-12-14-**	40
PMX-8-M12-1.5-RK	8	8	M12	1.5	细牙	30	13.8	24	9	20.5	6	12	18	6/22	4660	PXCS-12-14-**	42
PMX-8-M16-1.5-RK	8	8	M16	1.5	细牙	30	19.6	24	9	20.5	8	17	24	6/22	4660	PXCS-16-17-**	75
PMX-10-M16-1.5-RK	10	10	M16	1.5	细牙	30	19.6	26	9	22.5	8	17	24	4/27	7280	PXCS-16-17-**	80

PMXS-R 无锁定螺母 PMXS-RK 带锁定螺母

型号 不锈钢制	B	s	M		D	D1	L1	L2	L4 min.	Lb	sw	sw1	载荷(N) min./max.	销的 剪切载荷(N)	适用轴环 [PXCS] → P.xxxx	质量(g)	
			螺纹公称直径	螺距													
PMXS-3-M6-R	3	3.5	M6	1	粗牙	14	6.9	12	4.5	10	-	6	3/12	650	PXCS-6-7-**	4	
PMXS-3-M6-0.75-R	3	3.5	M6	0.75	细牙	14	6.9	12	4.5	10	-	6	3/12	650	PXCS-6-7-**	4	
PMXS-4-M6-R	4	4	M6	1	粗牙	14	6.9	12	4.5	10	-	6	3/12	1160	PXCS-6-7-**	4	
PMXS-4-M8-1-R	4	4.5	M8	1	细牙	18	9.2	16	6	13.5	-	8	5/24	1160	PXCS-8-10-**	8	
PMXS-5-M8-R	5	5	M8	1.25	粗牙	18	9.2	16	6	13.5	-	8	5/24	1820	PXCS-8-10-**	9	
PMXS-5-M8-1-R	5	5	M8	1	细牙	18	9.2	16	6	13.5	-	8	5/24	1820	PXCS-8-10-**	8	
PMXS-5-M10-1-R	5	5	M10	1	细牙	18	11.5	16	6	13.5	-	10	5/24	1820	PXCS-10-12-**	13	
PMXS-6-M10-R	6	6	M10	1.5	粗牙	24	11.5	20	7.5	17	-	10	5/21	2620	PXCS-10-12-**	17	
PMXS-6-M12-1.5-R	6	6	M12	1.5	细牙	24	13.8	20	7.5	16.5	-	12	5/21	2620	PXCS-12-14-**	23	
PMXS-8-M12-R	8	8	M12	1.75	粗牙	30	13.8	24	9	20.5	-	12	6/22	4660	PXCS-12-14-**	30	
PMXS-8-M12-1.5-R	8	8	M12	1.5	细牙	30	13.8	24	9	20.5	-	12	6/22	4660	PXCS-12-14-**	30	
PMXS-8-M16-1.5-R	8	8	M16	1.5	细牙	30	19.6	24	9	20.5	-	17	6/22	4660	PXCS-16-17-**	55	
PMXS-10-M16-1.5-R	10	10	M16	1.5	细牙	30	19.6	26	9	22.5	-	17	4/27	7280	PXCS-16-17-**	60	
PMXS-3-M6-RK	3	3.5	M6	1	粗牙	14	6.9	12	4.5	10	3.2	6	10	3/12	650	PXCS-6-7-**	5
PMXS-3-M6-0.75-RK	3	3.5	M6	0.75	细牙	14	6.9	12	4.5	10	3.2	6	10	3/12	650	PXCS-6-7-**	5
PMXS-4-M6-RK	4	4	M6	1	粗牙	14	6.9	12	4.5	10	3.2	6	10	3/12	1160	PXCS-6-7-**	5
PMXS-4-M8-1-RK	4	4.5	M8	1	细牙	18	9.2	16	6	13.5	4	8	13	5/24	1160	PXCS-8-10-**	11
PMXS-5-M8-RK	5	5	M8	1.25	粗牙	18	9.2	16	6	13.5	4	8	13	5/24	1820	PXCS-8-10-**	11
PMXS-5-M8-1-RK	5	5	M8	1	细牙	18	9.2	16	6	13.5	4	8	13	5/24	1820	PXCS-8-10-**	11
PMXS-5-M10-1-RK	5	5	M10	1	细牙	18	11.5	16	6	13.5	5	10	17	5/24	1820	PXCS-10-12-**	19
PMXS-6-M10-RK	6	6	M10	1.5	粗牙	24	11.5	20	7.5	17	5	10	16	5/21	2620	PXCS-10-12-**	22
PMXS-6-M12-1.5-RK	6	6	M12	1.5	细牙	24	13.8	20	7.5	16.5	6	12	18	5/21	2620	PXCS-12-14-**	31
PMXS-8-M12-RK	8	8	M12	1.75	粗牙	30	13.8	24	9	20.5	6	12	19	6/22	4660	PXCS-12-14-**	38
PMXS-8-M12-1.5-RK	8	8	M12	1.5	细牙	30	13.8	24	9	20.5	6	12	18	6/22	4660	PXCS-12-14-**	40
PMXS-8-M16-1.5-RK	8	8	M16	1.5	细牙	30	19.6	24	9	20.5	8	17	24	6/22	4660	PXCS-16-17-**	76
PMXS-10-M16-1.5-RK	10	10	M16	1.5	细牙	30	19.6	26	9	22.5	8	17	24	4/27	7280	PXCS-16-17-**	78

无尘洗净·无尘包装 → P.xxxx

防松动 → P.xxxx

激光刻印 → P.xxxx

欢迎洽询

可对应, 费用另计

不可对应